

STAHL'S[®]
ASIA • PACIFIC • AUSTRALIA

CLAM BASIC

OPERATING MANUAL



CONTENT

SAFETY INSTRUCTIONS	4
PREFACE TO THE MANUAL	5
DETAIL PICTURE	6
TURNING THE SYSTEM ON	7
CONTROL PANEL	8
ADJUSTING TEMPERATURE & TIME	9
ADJUSTING PRESSURE	10
PRINTING / PRESSING	11

This manual has been designed to be user friendly. Read it carefully, and follow the step-by-step instructions to get the best possible printing results.

- Work very carefully and avoid contact with the hot plate to avoid serious burns. Keep hands clear off heat platen while closing the press to prevent bruises and burns.
 - Use your press only on stable, steady and non-slip surfaces.
 - Check the press immediately after unpacking for any transport damage. Allow the press to stand for several hours at room temperature before using to prevent the formation of condensation, and thus avoid the risk of a possible short circuit.
 - Operate the press whilst standing, with both hands on the handle provided for this purpose. The machine should stand at a level that is adapted to the height of the operator.
 - The optimum operating condition for your press is at a maximum humidity of 70 %, and an ambient temperature between +15 °C and +50 °C.
 - Should any liquid or solid object get inside the unit, immediately disconnect the power plug from the wallsocket/outlet, and have the machine checked carefully by an expert before it is used again.
 - No liability is assumed by the manufacturer for any improper or nonintended use of the machine resulting in property or personal injury.
-

SAFETY INSTRUCTIONS

Important Safety Instructions

Before you use your press, you should follow some basic precautions, including the following:

- Read the complete manual before you start to use your press. Use the press exclusively for printing textiles, or other suitable products that do not contain heat sensitive components, and have not been treated with chemical additives.
- Keep your press secure from rain, moisture, dirt, dust, direct sunlight, mechanical vibration or shock, as well as keeping it well away from highly flammable or explosive materials.
- Never pull on the power cord to turn off your press, but always use the ON/OFF switch.
- If the machine will not be used for long periods of time, pull the plug carefully from the wall socket.
- The power cord must not come into contact with the hot plate (upper platen).
- Never use your press with a damaged or defective power cable. In the event of any damage or defect, never remove the casing of your press, but discuss the problem with a specialist who may be contacted during normal business hours by telephoning (+49) 0 68 31/97 33 0.
- Opening the case will void the warranty on the press.
- Avoid using the press in locations where children, or third parties have unsupervised access to the press. The minimum distance for children, or other persons should be at least 1.5 m away from the press to prevent burns and bruises.
- When lifting the press for any reason you should grip the machine and not the casing, as the casing contains plastic and delicate electronic components. Hold the press at the base plate, or directly on the bottom. The press must be completely cool and transported in the original box.
- Before connecting the power cable check that the operating mains voltage will be 230 V. The outlet must be fused with at least 10 amps. You should only connect one machine to a mains socket, and not use an extension lead.
- When using the machine for printing, it should never be left unattended (danger of fire). Please take care when loading the machine that it is fully open to avoid any burns.

Keep these instructions in a safe place.

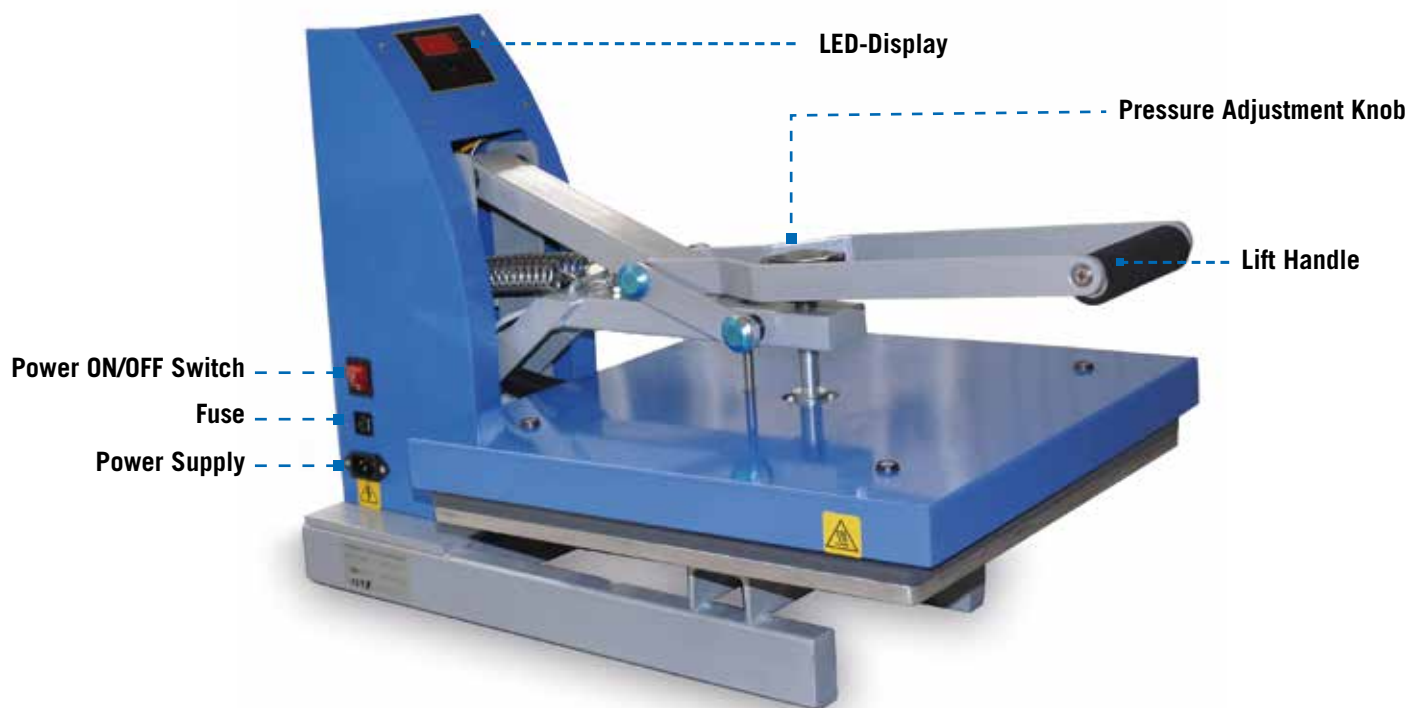

TURNING THE SYSTEM ON

Connecting the Power Cord

Ensure that the operating voltage of the mains supply is 230 V before connecting the machine. The socket must be secured with at least 10 amps. Only connect one machine per socket. Do NOT use extension cords, as this can lead to overheating of the cable (fire hazard), or to a loss of voltage.

Turning the system on

Open the press.

- Locate the ON/OFF switch on the back of the housing of your machine.
- Turn the switch to ON.

If your Clam Basic switches itself off, restart the machine by pressing the power switch twice to turn it off and back on again. Proceed by closing and opening your press once before continuing to print.

If the power cord is damaged, it must be replaced by the Manufacturer or by a technical member of staff, to avoid the risk of an electric shock. Use a HSJ Power Cord with 250V - 10AMP for replacement.

NOTE

Safety Switch / Fuse

The number on the safety switch indicates the amp at which the safety switch will release. During a power overload, the switch will „pop out“, interrupting the power supply. Push the button until it locks to reconnect the power supply.

Failure to observe this information may result in erratic controller functions, inaccurate displays and slow heat-up, the circuit breaker disengaging.

Please consider this when replacing.

WARNING



Power:	240 Volt, 1800 Watt
Digital Timer:	1-999 seconds
Digital temperature control:	96-221°C
Size of heat platen:	11" x 15" 15" x 15" 16" x 20"
Weight:	approx. 28 kg approx. 31 kg approx. 40 kg

TECHNICAL DATA

ADJUSTING TEMPERATURE & TIME

Press the mode button on your control panel. The (SET) and (TEMP) lights located next to the display will illuminate indicating you are in the Adjust Temperature Mode.

Use the Minus (-) button or the Plus (+) button to lower or raise the temperature until the desired temperature appears in the display. You can set the temperature between 96°C and 221°C.

Press the mode button again to access the Adjust Time Mode. The (SET) and (TIME) lights will illuminate, indicating you are in the Adjust Time Mode. Adjust the time in the same manner that you adjusted temperature. The time can be set between 1 and 999 seconds.

Press the mode button to exit the time settings. The lights to the left of the display will turn off. The current temperature will be displayed and the machine will start to heat up. It takes around 12 minutes to reach 150° C. You can open the heat press while it heats up or you can keep it closed.

As long as one of the lights is lit next to the digital display the machine is in set up mode and **will not start heating up.**

NOTE

The pressure adjustment knob is located in the centre of the heat platen. Adjust the pressure by turning the screw clockwise to increase pressure and counter-clockwise to decrease pressure. If you are not satisfied with the printing results, change the pressure.

Adjust the pressure with the garment inside the closed press to get exact results.

REMEMBER

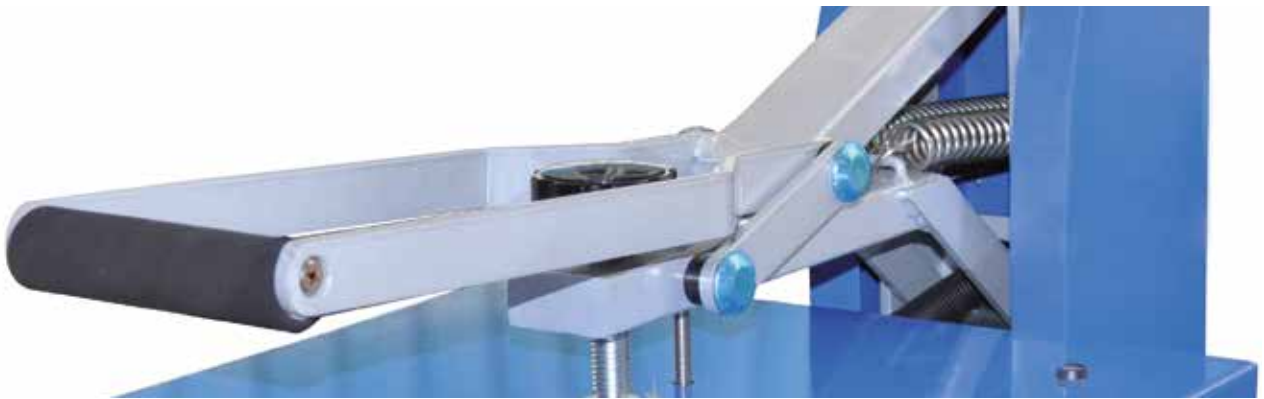

Structural damage caused by excessive pressure is not covered under the limited warranty!

WARNING

PRINTING / PRESSING

Once your machine has reached the designated temperature:

- Position the garment and application and proceed to press.
- Lower and lock the heat platen into the press position. This procedure will start the automatic timing process.
- The timer will automatically count down and audibly signal you to lift the heat platen into the “UP” position when the press cycle is complete.
- The time will automatically re-set and you are ready to continue with the next application.

23 °C The lowest temperature the unit will display.

96°C The lowest set temperature possible.

221°C The highest set temperature possible and the highest temperature the unit will lay.

NOTE

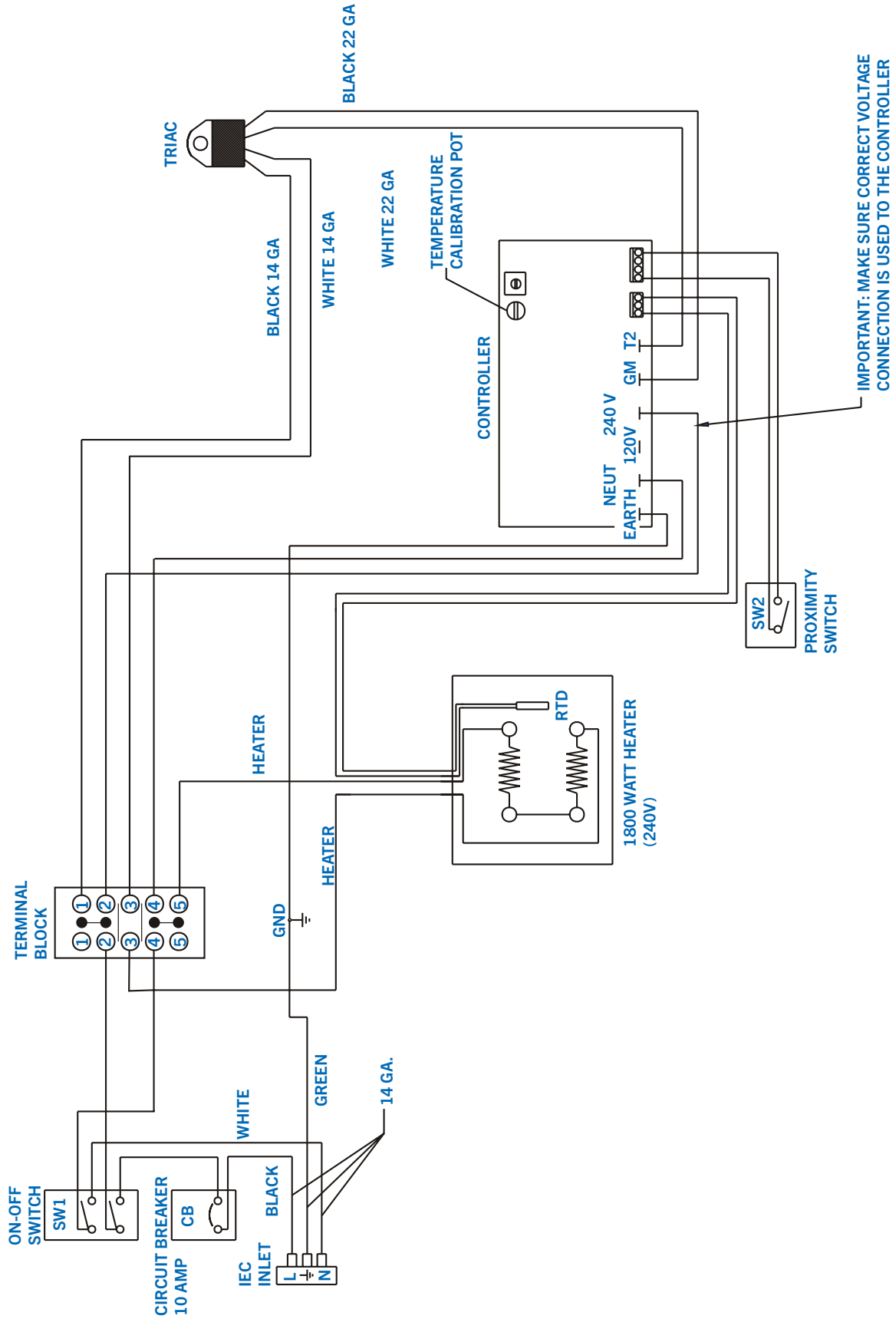

CONTACT

STAHL'S' Asia

8-79, Samseong 3-gil
Dongnam-gu
Cheonan-si
Chungcheongnam-do
Rep. of Korea

Technical Support & Customer Service

+82 41 622 0936

Email

info@stahlsasia.com

Web

stahlsasia.com